

Testing, dimming & parametrization of lightings

- Dimmable *with LED*
- Dimmable *with fluorescent tubes*
- For control units with following interfaces:
 - Analogue
 - Touch
 - DALI
 - DSI
 - DMX ...





Dimming of lighting

General

Test methods

Samples of lighting

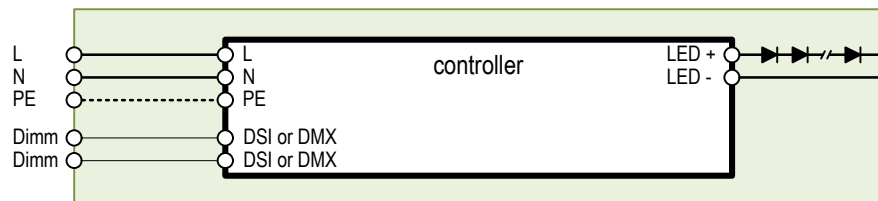
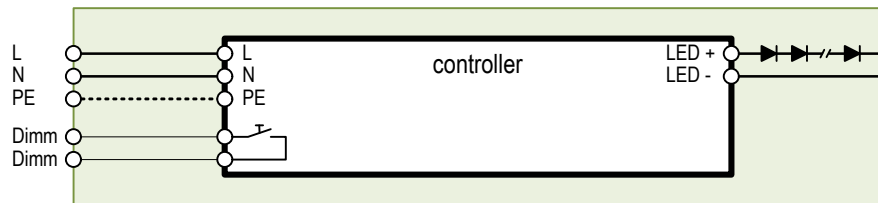
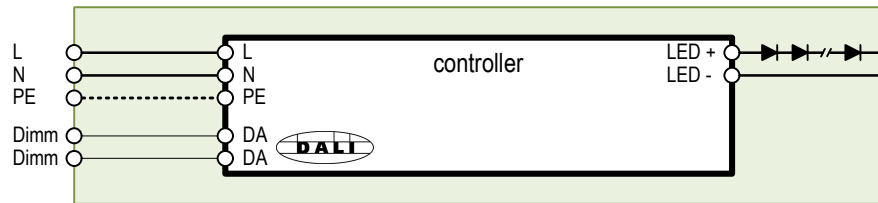
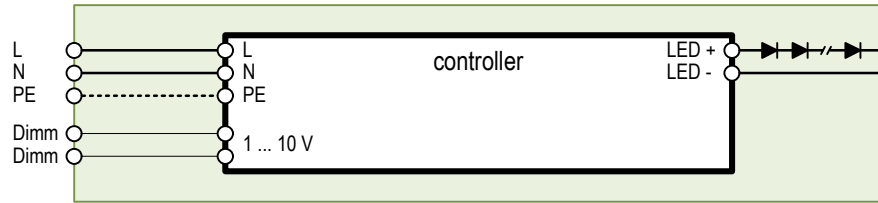

and more ...

Samples of possible connection variants of LED's and fluorescent lights

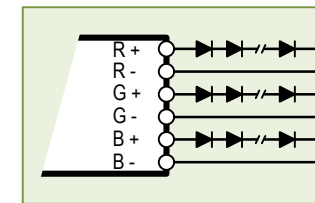
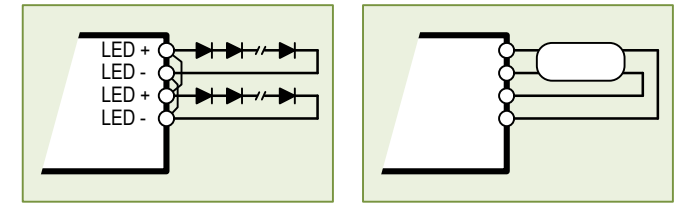

and more ...



Dimming of lighting

Test device connection

Test methods

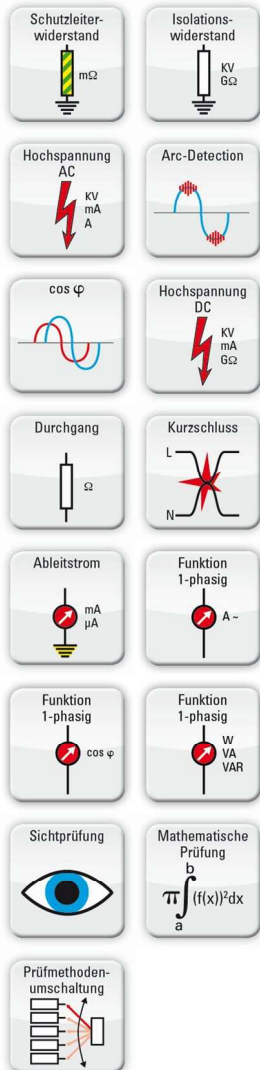

Typical connection configuration

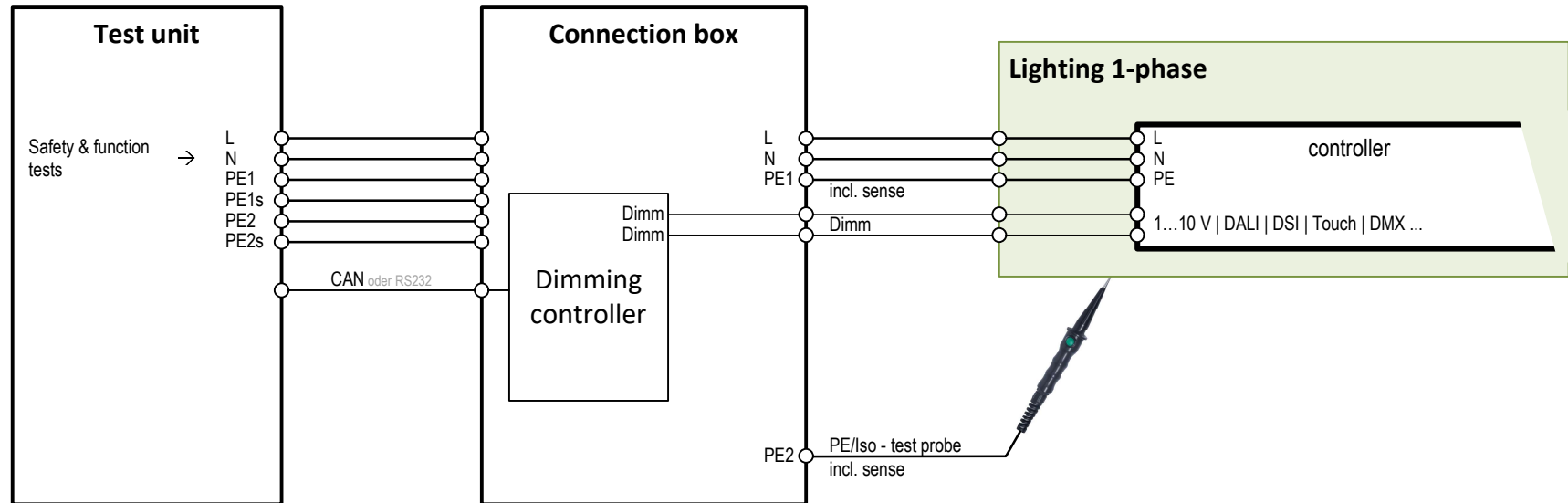



Dimming & parametrization of lightings

Principal hardware configuration

Test methods

Typical connection during programming / parametrization with a separate PC

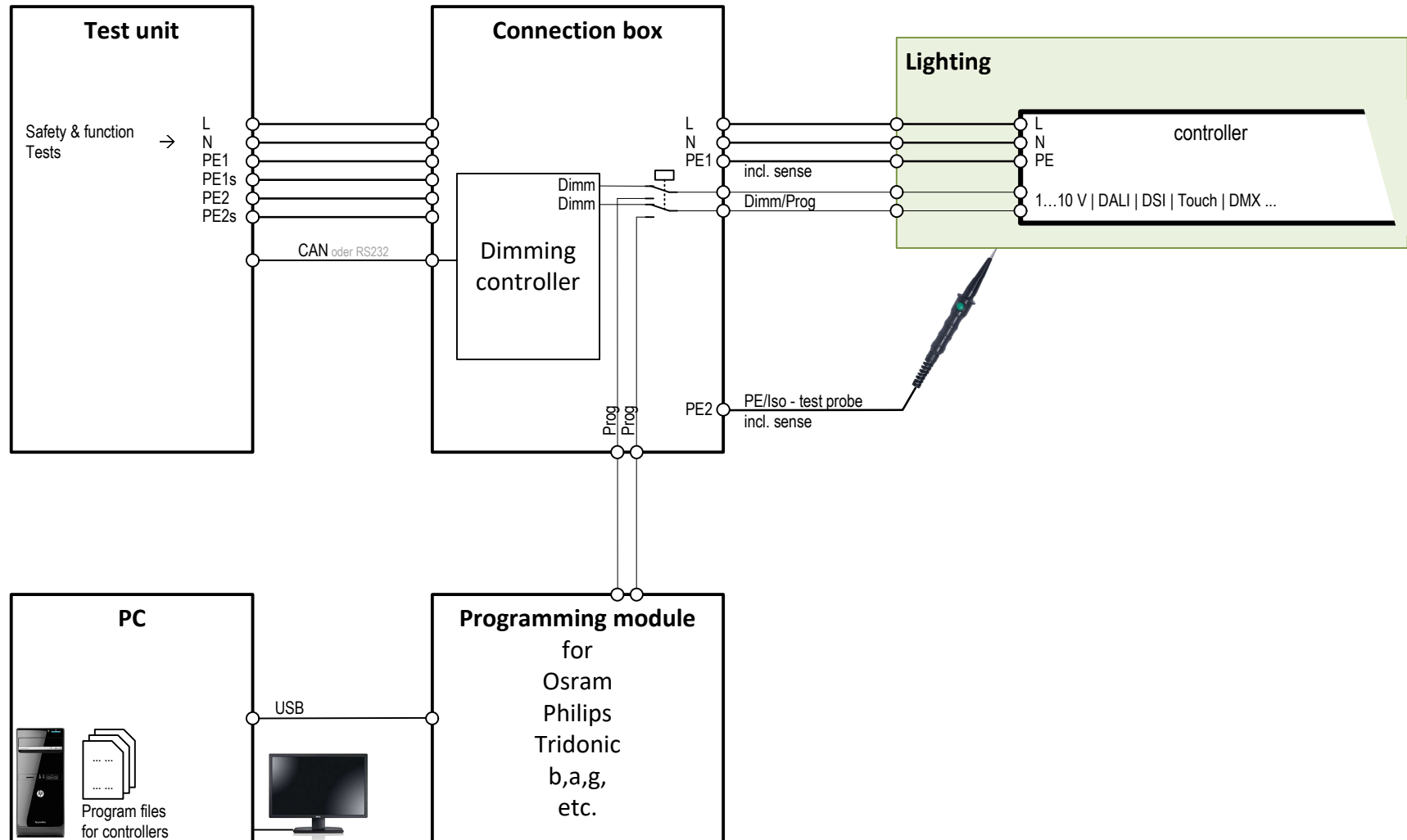



Dimming & parametrization of lightings

Hardware Konfiguration with GLP2/BASIC and technology package 1

Test methods

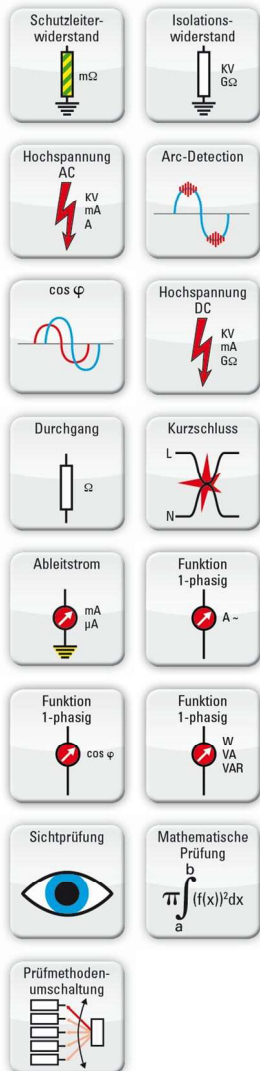

Typical connection configuration technology package 1

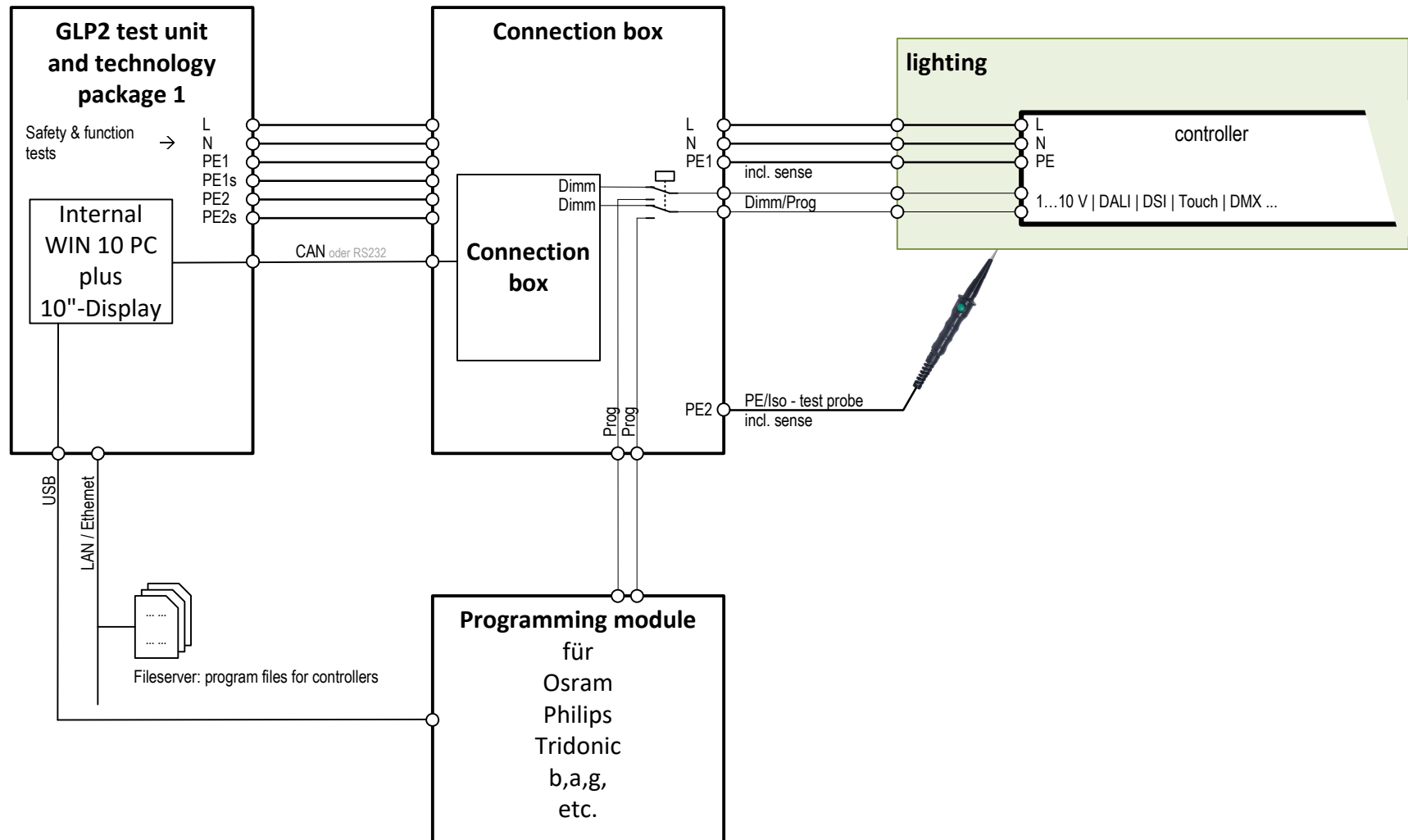



Dimming & parametrization of lightings

Hardware Konfiguration with GLP2/BASIC and technology package 2

Test methods

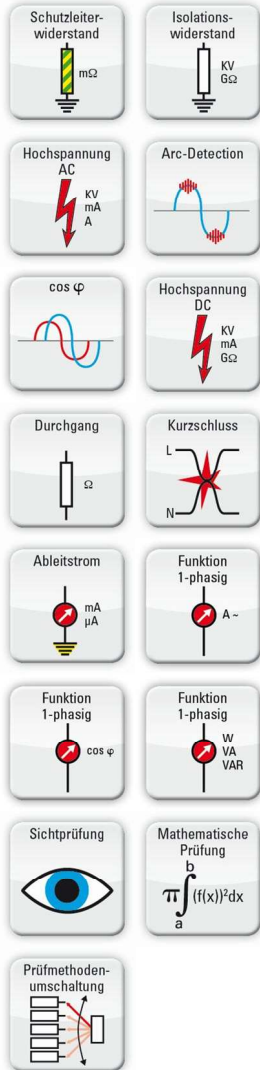

Typical connection configuration technology package 1

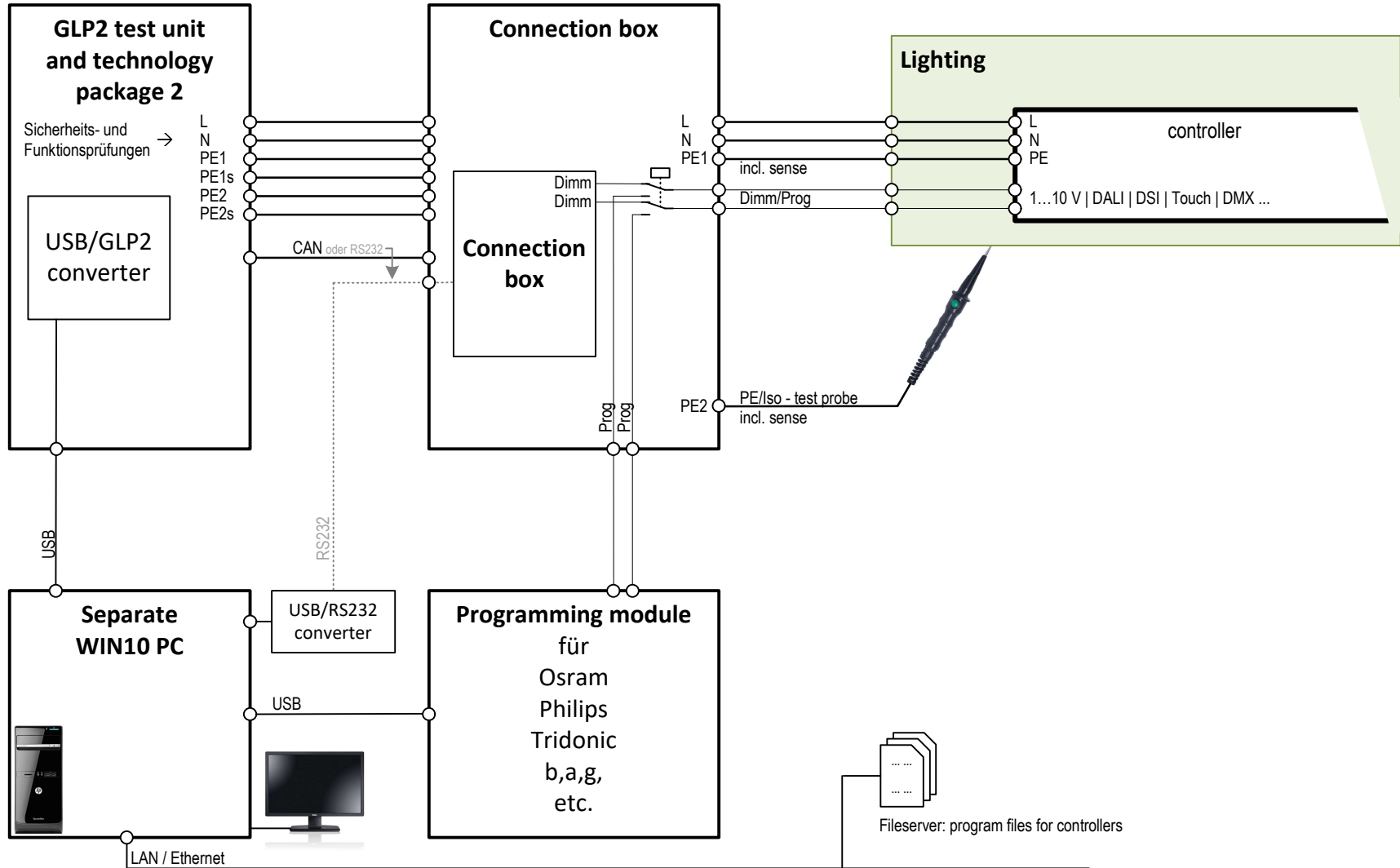



Dimming & parametrization of lightings

Hardware Konfiguration with GLP3

Test methods

Typical connection configuration with GLP3

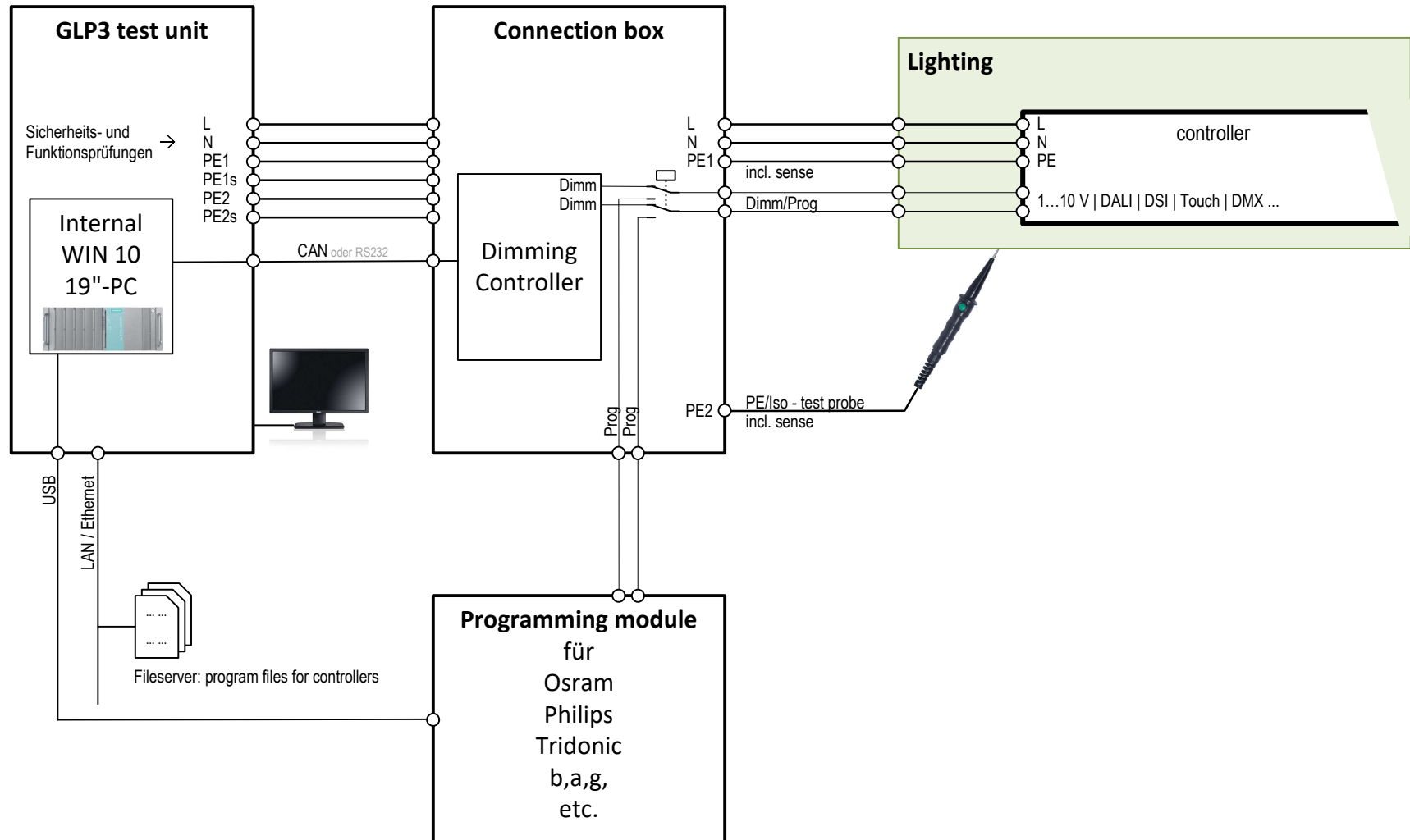



Dimming & parametrization of lightings

Test unit in combination with SAP

Test methods

Typical configuration with SAP integration | possible with GLP2 technology package 1 or 2 and GLP3

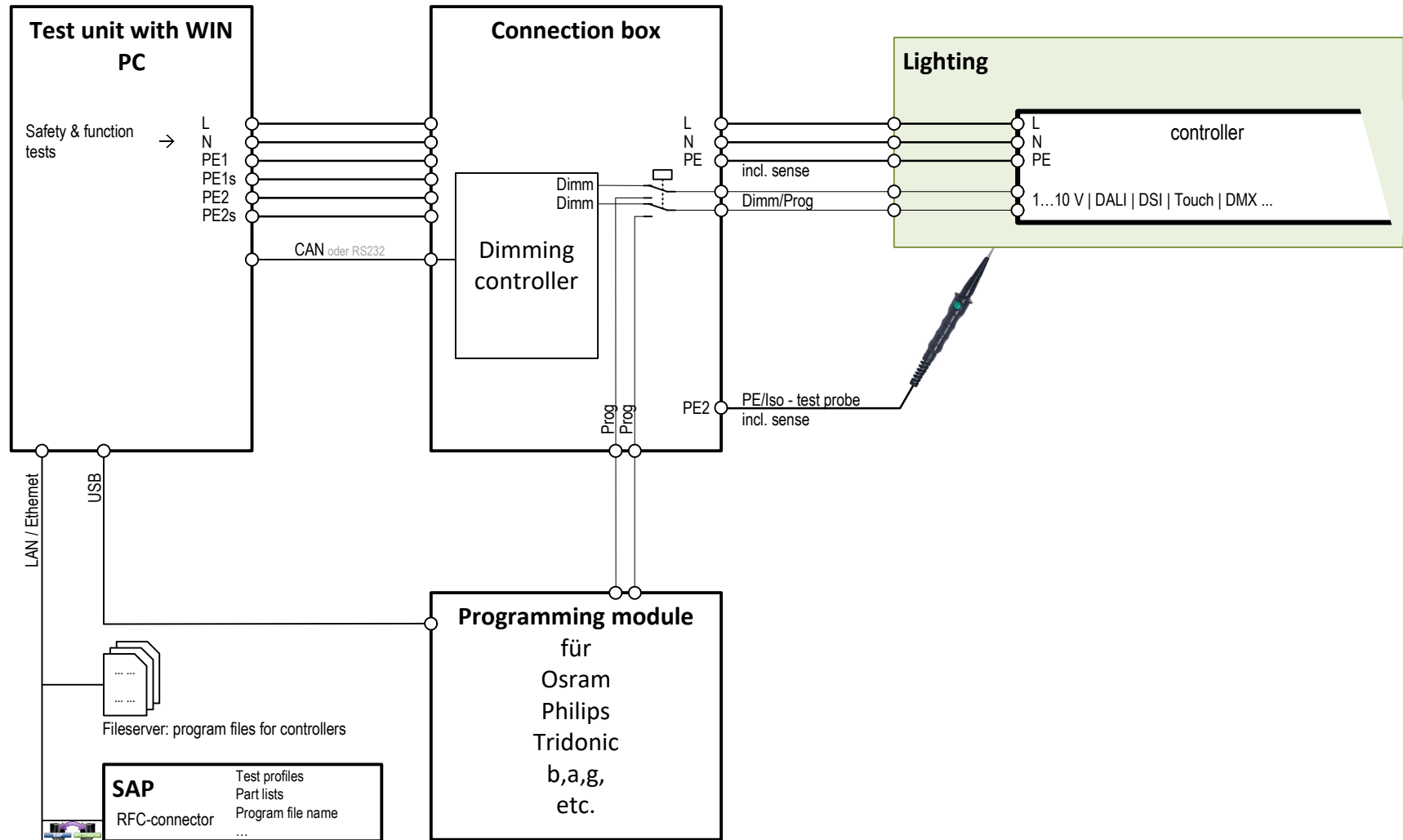



Storing, Network, communication

GLP2-BASIC, GLP2-ce modular

Local storing

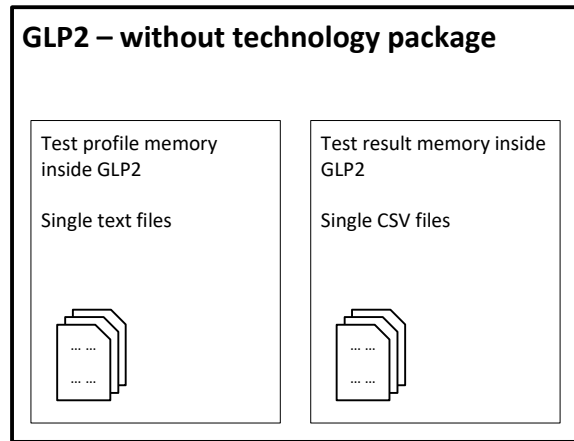

External storing via File Server PC

