

WHHPK - COMPREHENSIVE HYDRAULIC PULLER KITS



Capacities from 10 to 50 tonnes

Combination of 4 different pullers in one set

Quick set-up time, easy to use

The WHHPK heavy duty, multi-purpose hydraulic puller kit range is extremely versatile and includes 2-way and 3-way grip bearing pullers, bearing cup pullers and cross head pullers. All models are designed for pulling, pushing, installing and removing all press fitted or heat fitted parts such as gears, bearings, sleeves, cogs, internal bearings, wheels, sprockets, flywheels, etc. The range offers a selection of 4 models with pulling capacities up to 50 tonnes, all supplied complete with a full set of versatile, detachable hydraulic components.

- >> Working pressure 700 Bar
- >> Complete hydraulic system supplied, including gauge
- >> High quality, drop-forged steel components
- >> Supplied complete with carrying case

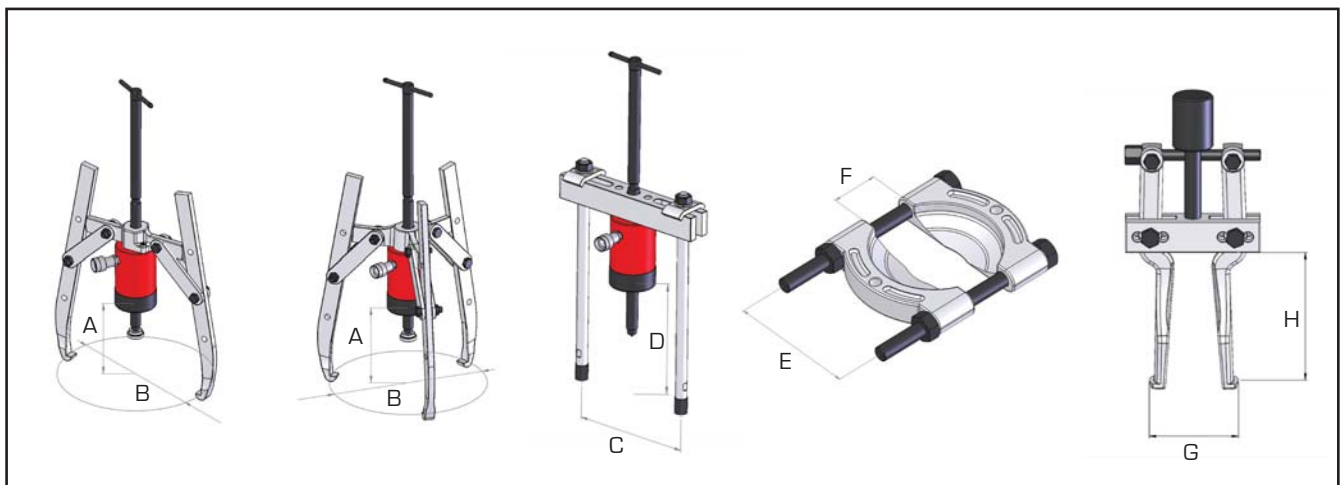

Model number	Capacity tonnes	Cylinder model no.	Pump model no.	Weight kg
WHHPK-1	10	S102	110	25
WHHPK-2	20	S202	110	60
WHHPK-3	30	S302	110	116
WHHPK-4	50	S603	227	268

Dimensions in mm										
A	B	C	C	D	E	F	F	G	G	H
		Min	Max			Min	Max	Min	Max	
296	350	115	260	300	110	10	110	40	145	115
320	480	135	345	265	152	11	134	40	145	115
407	580	180	440	284	260	15	250	60	240	150
727	920	230	580	447	260	15	250	60	240	150

Dimensions A & B calculated with 15° outward angled puller legs.